

LJ 'NON-MARKING' PLATE CLAMPS



The LJ non-marking plate clamps are designed for lifting, turning and transporting of structural steel plates, stainless steel, iron, timber and aluminium without marking, damaging or leaving indentations on the surface. It can also be used for steel plates with extremely hard surfaces.

These clamps are available with two different types of pads, rubber or leather. The type to be used is dependant on the surface of the material being gripped. If you have any concerns regarding the best option for your application please contact our sales team for advice.

These plate clamps are service-friendly, making it easy to exchange parts, which are readily available. Clamp repairs are available through the factory, or can be done by a competent person.

NB: The surface of the material being gripped must be free of oil, grease or any other liquid to ensure safe transport.

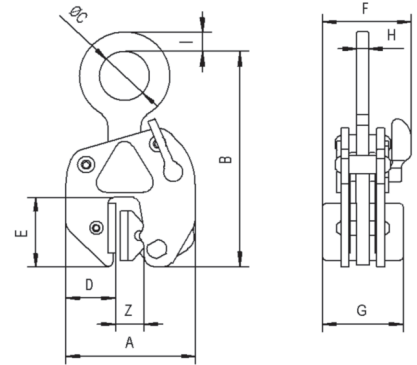

Model	WLL kg*	Jaw capacity mm	A mm	B mm	C mm	D mm	E mm	F mm	G mm	H mm	I mm	Weight kg**
LJ 500	25 - 500	0 - 10	127	200	50	52	69	86.5	76	13	20	3.5
LJ 1500	180 - 1500	0 - 20	215	345	85	75	135	131	118	20	24	12

*Per clamp.

**Weight per clamp.

TSB NON-MARKING 'FRICTION' PLATE CLAMPS



The TSB non-marking plate clamps with chain are designed for vertical lifting and transporting of plate material. This particular range of clamps has a large jaw capacity that enables it to be used on a multitude of applications.

The main feature of the TSB plate clamps is the fact that it is non-marking. It works through the process of 'friction'. This is achieved by a special material on the jaw and pad which is similar to brake linings.

Another benefit of the TSB, is that one grab can be used for lifting different materials such as concrete, wood, stone, and hardened steel.

These plate clamps are service-friendly, making it easy to exchange parts, which are readily available. Clamp repairs are available through the factory, or can be done by a competent person.

NB: The surface of the material being gripped must be free of oil, grease or any other liquid to ensure safe transport.

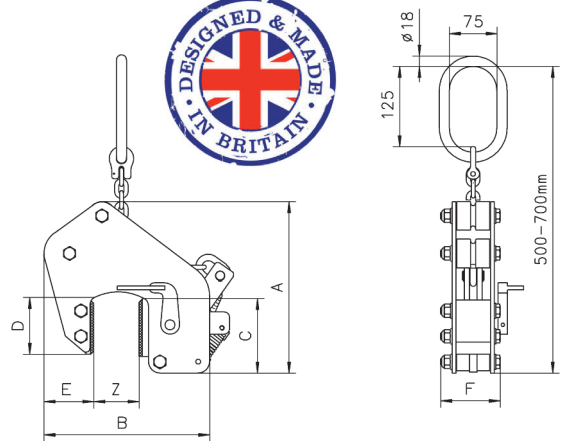

Model	WLL kg*	Jaw capacity mm	A mm	B mm	C mm	D mm	E mm	F mm	Weight kg*
TSB 350/65	20 - 350	0 - 65	270	260	128	100	65	78	8
TSB 750/65	40 - 750	0 - 65	270	260	128	100	65	78	9
TSB 1250/65	125 - 1250	0 - 65	270	260	128	100	65	78	12

*Per clamp.