

# CZ 'HEAVY DUTY' VERTICAL PLATE CLAMPS

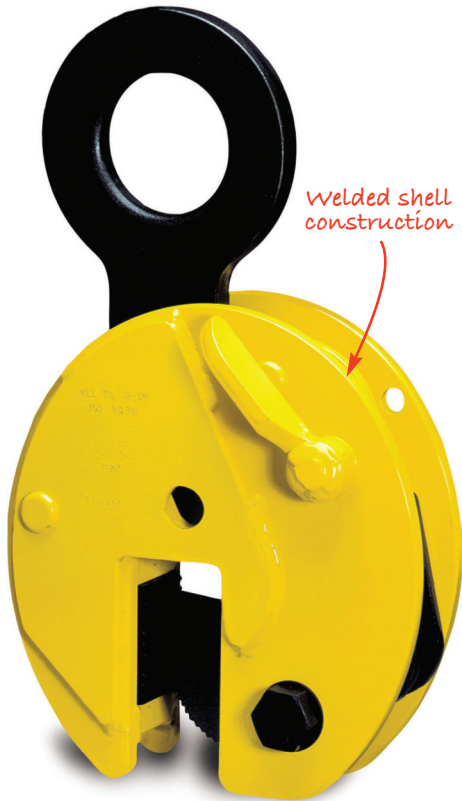

**NB: The plate surface of the material being clamped must have a hardness level below HRC 30/Brinell 300.**

## Heavy duty plate clamps with safety lock

Working load limit (WLL) 1000 - 30000kg

These clamps are primarily used for transporting sheet metal and steel plates in the vertical position, as well as lifting and rotating through 180°.

They can also be used for transporting steel constructions and profiles. It is recommended to use a pair of plate clamps in conjunction with a spreader beam for long materials which have a tendency to sag or flex.

### Function

The jaw is opened and closed with the locking lever. The safety lock spring loads the cam jaw, preventing the clamp from opening even when there is no load.

### Workmanship and parts

These plate clamps are service-friendly, making it easy to exchange parts, which are readily available. Clamp repairs are available through the factory, or can be done by a competent person.

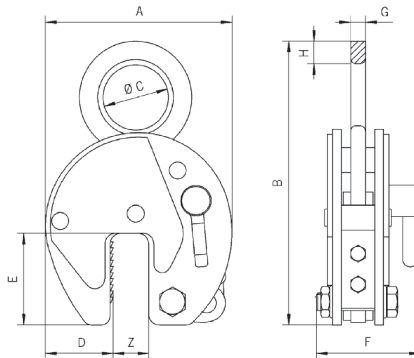

Model	WLL kg*	Jaw (Z) capacity mm	A mm	B mm	C mm	D mm	E mm	F mm	G mm	H mm	Weight kg**
CZ 1	100 - 1000	0 - 20	140	254	51	48	70	83	13	19	4
CZ 2	200 - 2000	0 - 32	197	323	67	68	93	110	20	20	11
CZ 3	300 - 3000	0 - 32	197	371	80	68	93	110	20	30	12
CZ 3L	300 - 3000	30 - 60	228	390	80	68	93	110	20	30	15
CZ4	500 - 4000	0 - 32	197	371	80	68	93	129	20	30	12
CZ 4L	500 - 4000	30 - 60	228	390	80	68	93	129	20	30	18
CZ 6	700 - 6000	0 - 50	293	484	89	95	143	129	25	35	21
CZ 6L	700 - 6000	50 - 100	362	524	89	95	143	129	25	35	28
CZ 8	950 - 8000	0 - 50	293	492	89	95	143	129	25	42	26
CZ 8L	950 - 8000	50 - 100	362	524	89	114	143	129	25	42	32
CZ 10	1500 - 10000	0 - 50	293	545	110	95	143	139	25	45	30
CZ 10L	1500 - 10000	50 - 100	362	545	110	114	143	139	25	45	37
CZ 12	1800 - 12000	0 - 50	360	613	130	125	162	154	30	55	54
CZ 12L	1800 - 12000	50 - 100	460	678	130	175	162	154	30	55	63
CZ 15	3000 - 15000	0 - 50	360	613	130	125	162	204	45	55	75
CZ 15L	3000 - 15000	50 - 100	460	678	130	175	162	204	45	55	88
CZ 20	4000 - 20000	0 - 65	462	755	130	165	210	235	45	65	123
CZ 20L	4000 - 20000	65 - 130	560	805	130	195	210	235	45	65	136
CZ 30	6000 - 30000	0 - 65	462	732	60	165	210	295	65	-	195
CZ 30L	6000 - 30000	65 - 130	560	797	60	195	210	295	65	-	295

**PLEASE NOTE: Units are supplied as standard with a hook ring. Link fitting and chain are available on request as a special order. Also available with 'Sharp Leg' body shell or extra thick shell plates for dragging. Please contact sales team for further details and prices.**  
 \*Per clamp. \*\*Weight per clamp with hook ring. \*\*\*Standard length of chain = 4-6 links.